

# NewClassD

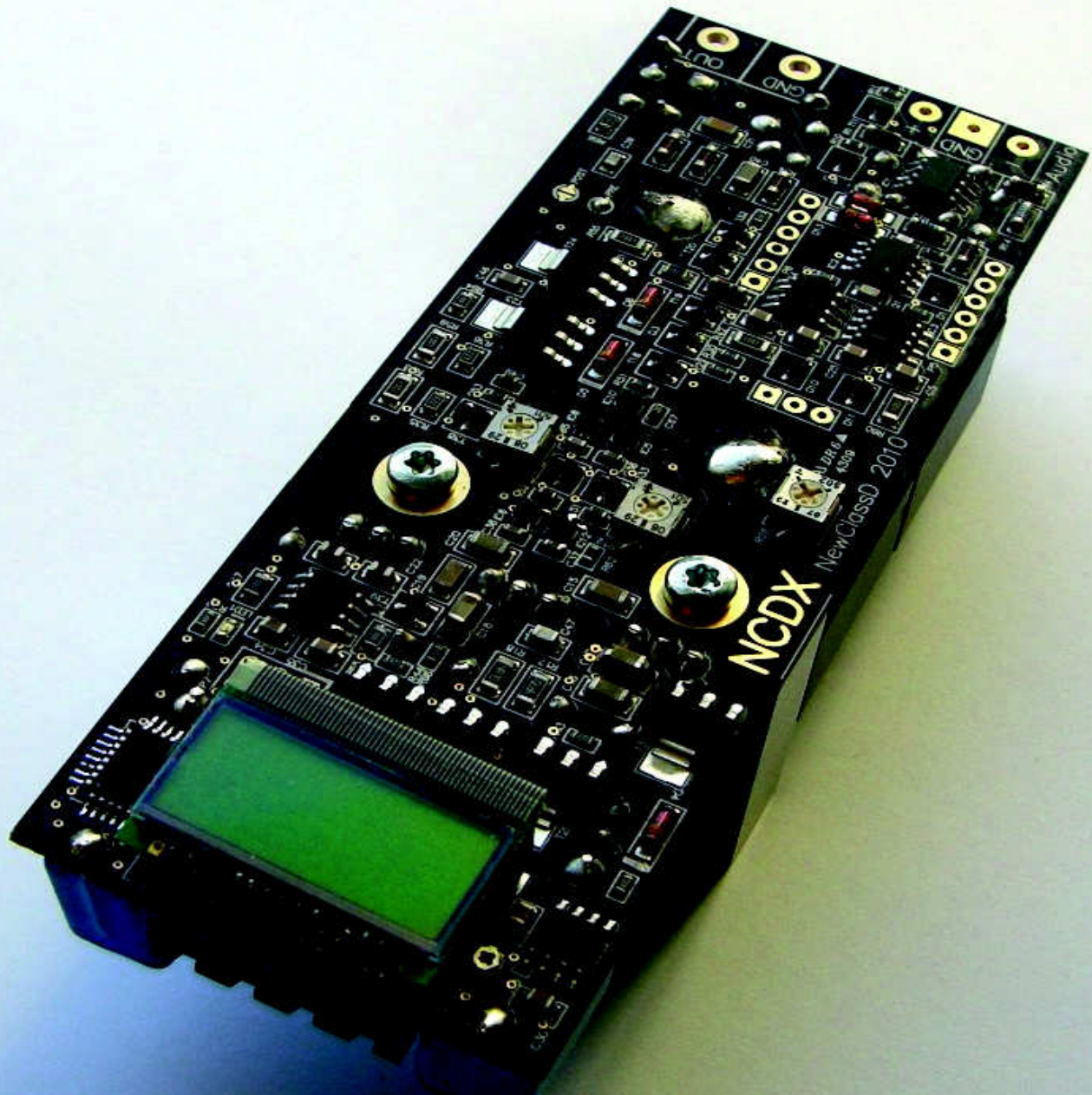

# Cookbook

ver 2.01 - 2011

NCDX Advanced Class D Amplifier for DIY Construction

## Index

Basic system implementation	5
Before you begin	3
Building step by step	6
Electrical Safety	6
EMC Considerations	11
Here is what you need to build a complete amplifier	4
Internal Wiring properties and connections	10
Legal Notice on warranty	3
Mechanical Layout	4
Never do this	3
NewClassD Power Supply Modules	8
OPTION Balanced Input	17
OPTION Dual Mono power amplifier configuration	21
OPTION External power supply for input stages	18
OPTION Feedback topology	14
OPTION Micro Preamp based on OPA627	16
OPTION Using a tube preamplifier	15
OPTION Using 4 pole capacitor to optimize sound	22
OPTION Volume Control / Passive preamp	16
Other tips	23
Residuals	13
Selection of Power Transformer	4
Soft Start circuit for the NCDX	7
Turn on for the first time	12

## NewClassD

Brand of  
**DEXA Technologies ApS**  
Christiansgade 1  
DK 7500 Holstebro  
Denmark

tel +45 31139101  
e-mail: [sales@newclassd.com](mailto:sales@newclassd.com)  
paypal: [info@newclassd.com](mailto:info@newclassd.com)  
Released Aug. 2011

### Before you begin.

We provide first some 'Dont's. These are provided to give you a short and sweet of things you should avoid doing to your NewClassD modules during the construction of your new amplifier. We have placed these in the beginning of the cookbook only to make sure you see them, in case you should decide not to read the entire cookbook.

### Legal Notice.

NewClassD modules are covered by a limited warranty. In case a module malfunctions, your warranty will cover replacement of the module and other parts delivered by NewClassD, providing the instructions are regarded. No parts which are not delivered by NewClassD are covered by warranty, insurance or other in other way can become liability to NewClassD, it's holding company Dexa Technologies Ltd, or it's insurance companies.

### Never do this.

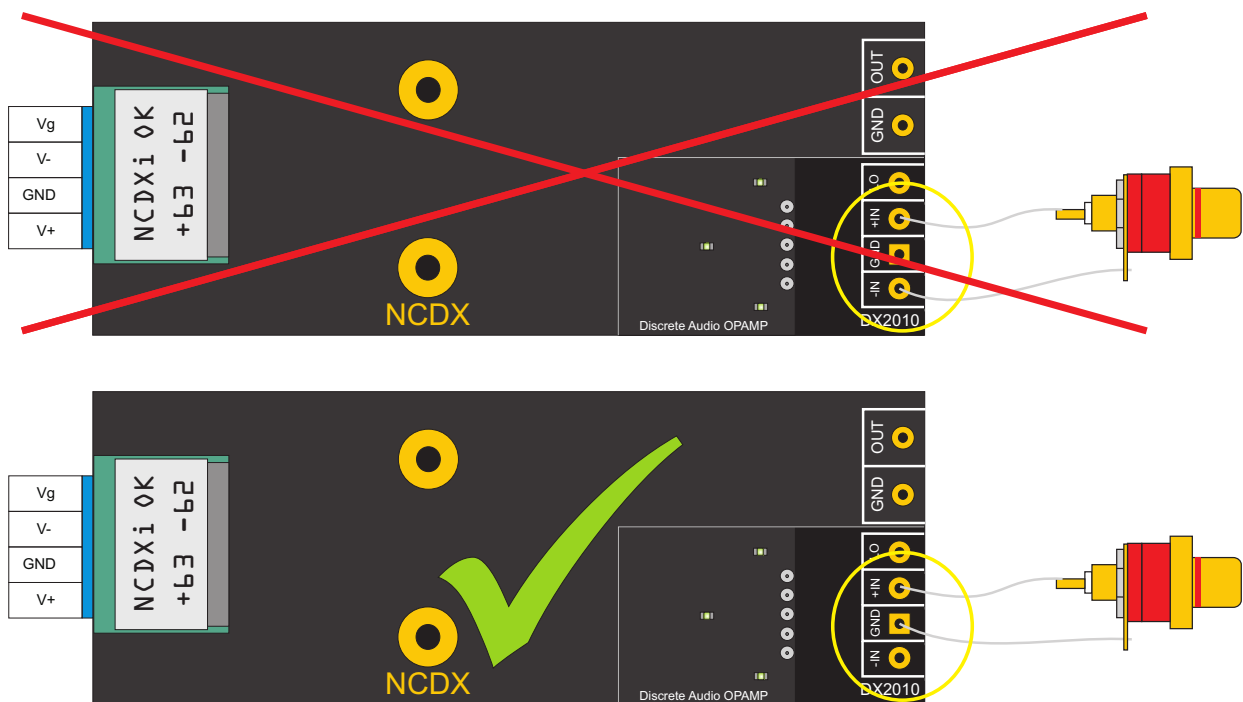

**Never** use the minus input terminal as GND for your input wire. If you are running unbalanced, short the minus input directly to the square GND terminal right next to it, and connect the screen to GND.

**Never** re-adjust the trimmers on the module, as this may damage the module in case of shoot-through.

**Never** use the module without proper heat sink attached

**Never** change feedback mode while the amplifier is plugged into the power supply module. Not even when mains is not connected, as a substantial charge on the capacitors may destroy the module.

**Never** connect the In-Circuit programming plug for the microprocessor to anything. This may disable the protection, or even damage the computer chip.

**Never** use both 'pre' and 'post' mode, when power is applied to the amplifier.

**Never** let metallic parts or liquids of any kind come in contact with the module's circuits, other than the connectors. Even when power is turned off.

## **Checklist.**

### **Tools required.**

Wire Cutter.  
Small Blade Screwdriver.  
Medium Pozidrive Screwdriver.  
TX20 Screwdriver or bit.  
Autocrimper (Can get from any gas station).  
Solder Iron and solder.  
Drill machine, and drills. (Maybe also a file for cleaning holes).

### **Here is what you need to build a complete stereo amplifier:**

2 NewClassD modules.  
1 Power Supply Module. (2 for Dual Mono).  
1 Power transformer (up to 2 x 42 V AC) with mounting hw. (2 for Dual Mono).  
1 Enclosure with heat dissipation capability.  
4 Speaker Binding Posts.  
2 RCA Phono plugs. (or XLR females for balanced inputs).  
1 IEC mains socket with fuse holder (and fuse 5-6.3 AT).  
3 x 1 m 12 gauge (2.5 mm<sup>2</sup>) single wire.  
~0.5m Speaker cable.  
~0.5m Signal cable (preferably screened).

### **Selection of power transformer.**

From a strict loading perspective the transformer does not have to be very big to produce a significant audio output. We usually say the transformer should at least be of the same power that you want out of your amplifier. This will keep everything safe. For ex. if you want 2 x 250 Watt RMS out, you can get by with a 500 VA transformer for 2 channels.

However a bigger transformer will give you sound improvements, so if you have no limitation on space, weight and budget, we recommend using a 630VA per channel, or a 1000 VA for a 2 channel amplifier. If your speakers are 4 Ohm, use a 2x40V AC, if your speakers are 8 Ohms you can go higher.

### **Building Step by Step.**

On the next pages you can find a simple step by step building instruction for a complete amplifier.

### **Mechanical layout.**

First lay down the components of your amplifier in your enclosure, to see how everything can be best fitted inside.

Take the following into consideration, in prioritized order: (If you don't follow these rules, you will not get an optimal result of your amplifier).

- 1..The base plate of the amplifiers, must have good cooling from the enclosure. A thin steel bottom plate is not enough cooling. In this case you must add a 6 by 8 inch (15 x 20 cm) aluminium plate to distribute heat. (Reliability issue!)
- 2..Wire distance between PSU and amplifiers must be SHORT! up to 4-6 inch (10-15cm) is ok!
- 3..Distance between Amplifier's / input wiring and mains transformer (and it's wires) must be as big as possible.
- 4..Wire distance of input signal and speaker cables should be as short as possible.
- 5..Wire distance between mains transformer and PSU should be short.

## Basic System implementation.

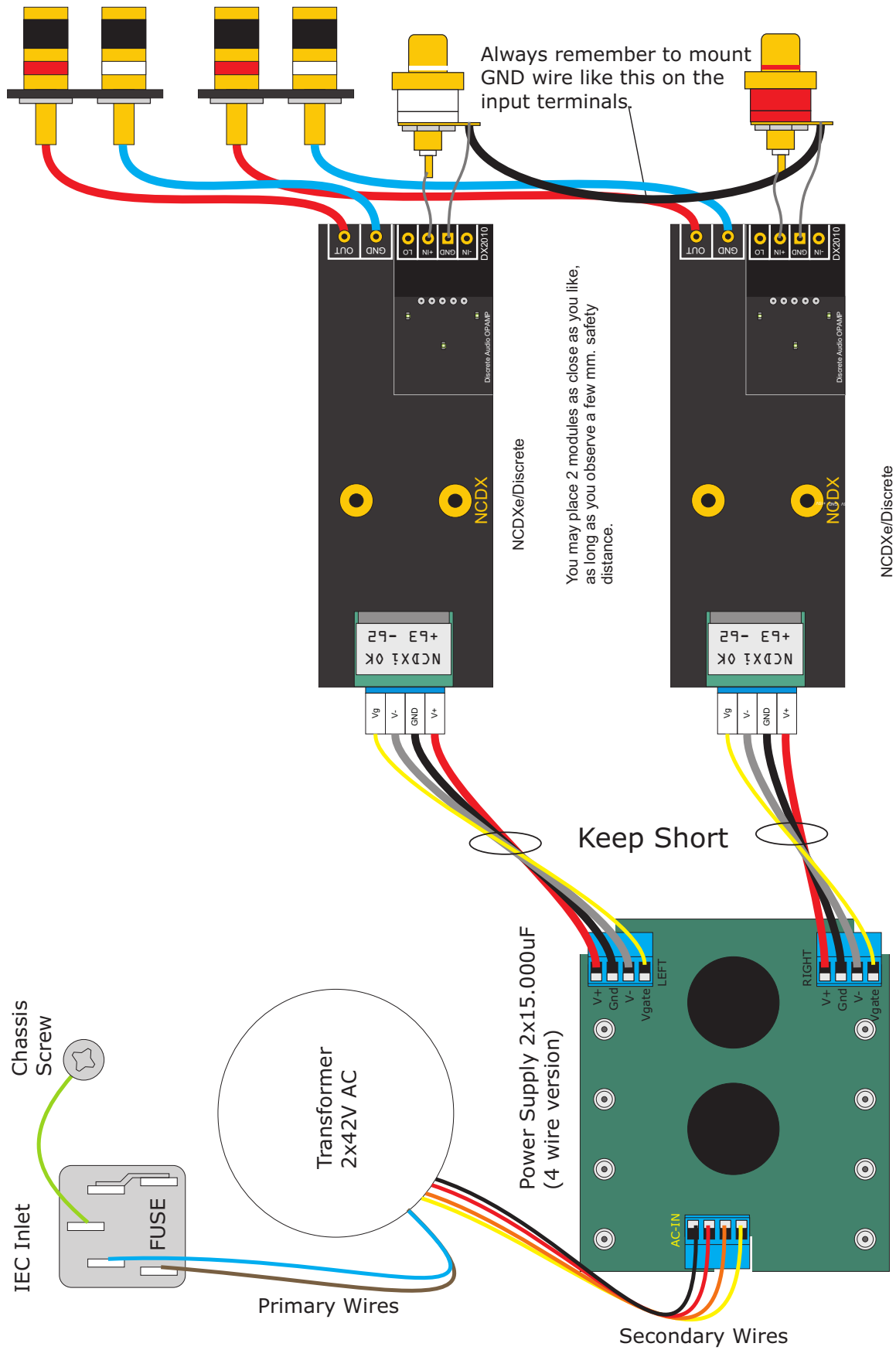

## STEP BY STEP

When you have all the parts for your new amplifier, and the tools required at hand, then start this step by step guide.

1..Place alle the hardware in the enclosure, where it fits best, and mark the position of the holes for drilling. Remember that at least the NCDX modules require heat sinking, by mounting them on a metal surface. (Only aluminum or copper is good enough heat conductor). If your enclosure is steel, we suggest you mount the modules on an internal aluminum plate, for best performance. The modules will dissipate about 12-15 Watts under all conditions, so it's not a lot of heat, but still needs to be taken into consideration.

2..Remove all the electronics modules from the enclosure, and drill the holes for fixing the modules. Mark up for the IEC inlet, and drill holes for that. You should also clean the hole up with a file before fixing the IEC inlet. Remember in all holes remove craters, and make the hole surface smooth, for good thermal contact.

### **Electrical Safety.**

Mainly an issue for the mains side of the transformer. Use only double insulated wiring, or single insulated wire with heatshrink. Crimp terminals / spades should be isolated, and also have heatshrink on top of that, after crimping them on the wire. Ensure all wires are securely fastened (by pulling ALL of them). Make sure you have AT ALL TIMES a mains fuse connected, when the amplifier is on. No bypassing. If you use a smaller AUX transformer for gate supply or preamplifier, it MUST HAVE it's own fuse with ~0.5-1 A rating. This fuse should be connected on the amplifier side of the main fuse, so in case the mains fuse blows, no power will pass through the smaller AUX fuse. Our soft start modules have a special AUX fuse for this purpose.

3..Now it's time to fix all the stuff inside the enclosure. Start with the plugs, and then the modules, and finish with the transformer.

Connection of the transformer: In most cases you can simply connect the transformer wires directly to the fused IEC inlet terminals with use of insulated crimp terminals. In case you have a mains transformer bigger than 500 VA you need a soft start circuit to protect the fuses and switches in the system from overloading at startup.

A soft start module slowly charges the mains capacitors and magnetizes the mains transformer, to preserve the fuses and switches. The full mains power is switched in after 1 second delay. Our soft start module now has microprocessor control, and will also double as an offline switch, so you can use a nice pushbutton switch with LED indicator for mains switch. Also DC filter function is embedded on the module.

## Soft Start Circuit for the NCDX module.

We offer a soft start circuit particularly suitable for NewClassD NCDX modules. This 'All-in-one' audio net interface also has a DC blocker (10000uF) and a RF frequency blocker, that prevents RF noise on the mains grid, while not affecting the sound of the amplifier. Also mains switch function is available, so a push button switch can be used to switch the mains on and off. Also an LED will show the status of the power switch.

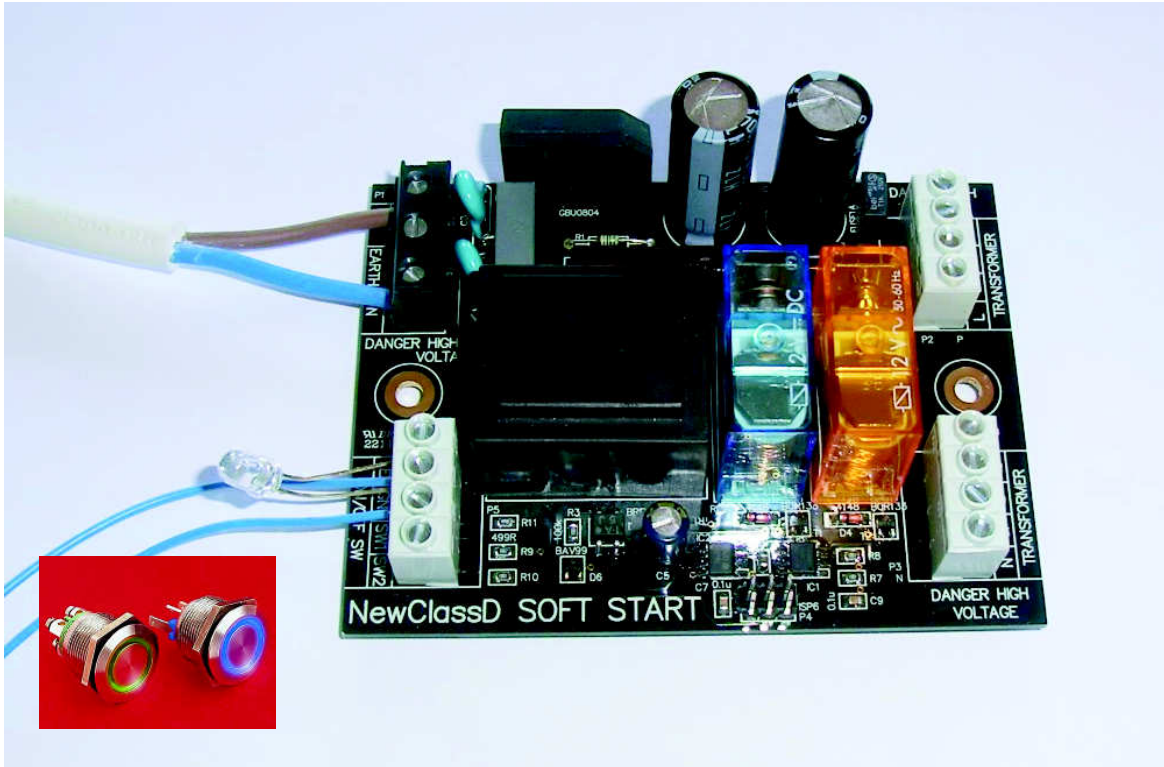

There is also a separate fused outlet for an AUX transformer which allows you to use a separate gate drive or preamplifier transformer with easy connection to the common mains.

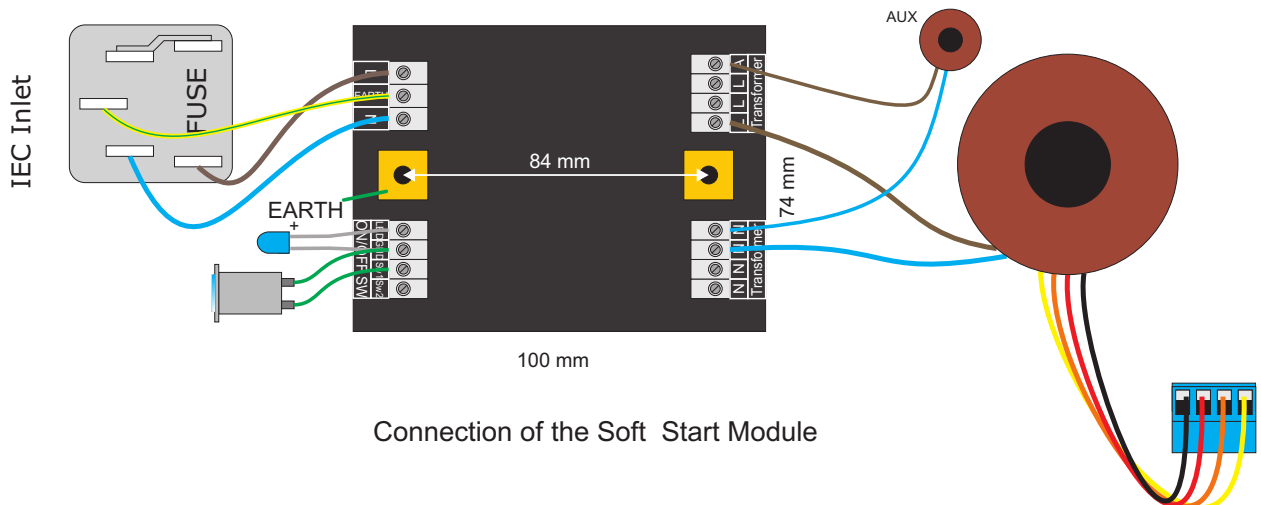

Connection of the Soft Start Module

## NewClassD Power Supply Modules

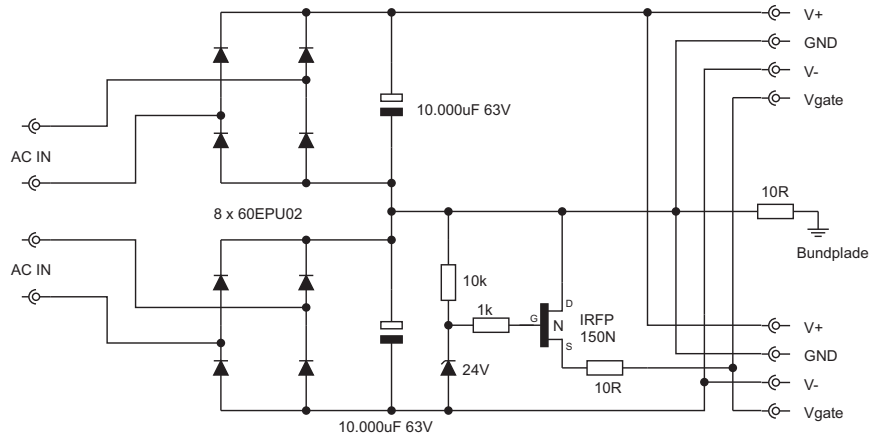

4 Wire power supply Schematic This model suitable for a standard transformer with 4 secondary wires.

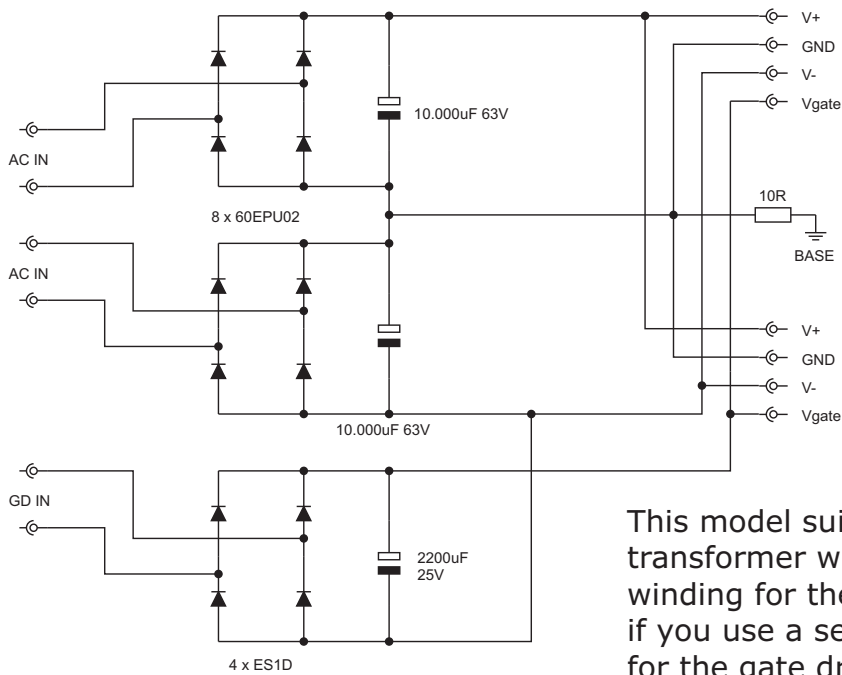

6 wire power supply Schematic

This model suitable for a special transformer with a separate winding for the Gate Driver, or if you use a separate transformer for the gate driver.

Center Tab Transformer:

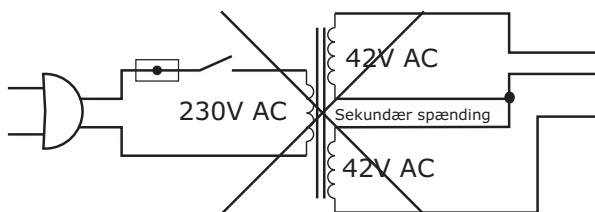

Transformers with 3 secondary wires cannot be used with these power supply configurations.



## 4 Wire or 6 Wire?

Two different versions are offered, one that makes use of a Gate Drive Winding on the main transformer, or a separate 15 V AC Gate Transformer, this is named the 6 wire type. It basically uses a total of 6 wires from the toroid transformer. Rectification of the gate drive voltage is performed also by low noise fast recovery diodes, to preserve the noiseless operation, with no magnetic interference of the amplifiers and sound.

The other version is the 4 wire type, for use with traditional 4 wire transformers, used in Class A/B amplifiers. These transformers have a standard 40V-0V 40V-0V configuration (Or other voltages). In this case the Gate Drive Voltage is derived from the GND level, by use of a lownoise analog regulator on the power supply module.

### How to choose...

It's very simple to choose 4 wire or 6 wire Power Supply:

If you have a transformer with 6 secondary wires, choose the 6 wire PSU.

If you have a transformer with only 4 secondary wires (most common), then choose the 4 wire PSU.

If you have a main transformer with 4 secondary wires, and a smaller aux transformer (15V 15 VA) for the Gate Drive, then choose the 6 wire PSU.

There is no sound difference of the two types, the only difference is that the 6 wire version runs a little cooler than the 4 wire version, but then it requires a special transformer to work. About 90% use the 4 wire version.

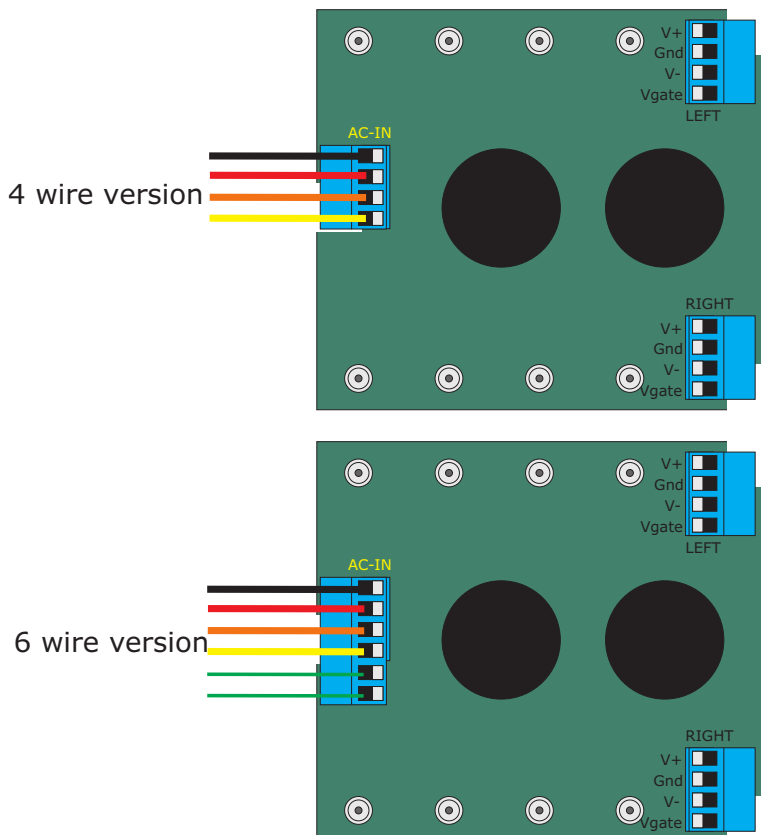

### Connection of Transformers to Power Supply.

There is not much to be said about these connections. If the colors coming out of the transformer differs from the drawing (yellow, orange, red, black) take a look on the label on the transformer to get the right colors for your transformer.

### Note!

You can NOT use a transformer with common center tab, like 42-0-42V, with our power supply modules. If you have a transformer like that, you must build a simple 'traditional' power supply with bridge rectifier and two caps.

### Connection of Power Supply to Amplifiers.

For +, - and GND use 12 gauge (2.5mm<sup>2</sup>) single wire, and keep it SHORT! If you have more than 6 inches, the sound quality will suffer. To ensure easy access we have provided plugs for these connections.

4.. Connect the transformer to the soft start or IEC connector. Connect all the audio wires, and connect the power supply to the modules. After connecting the power supply to the modules, check one more time just to be sure.

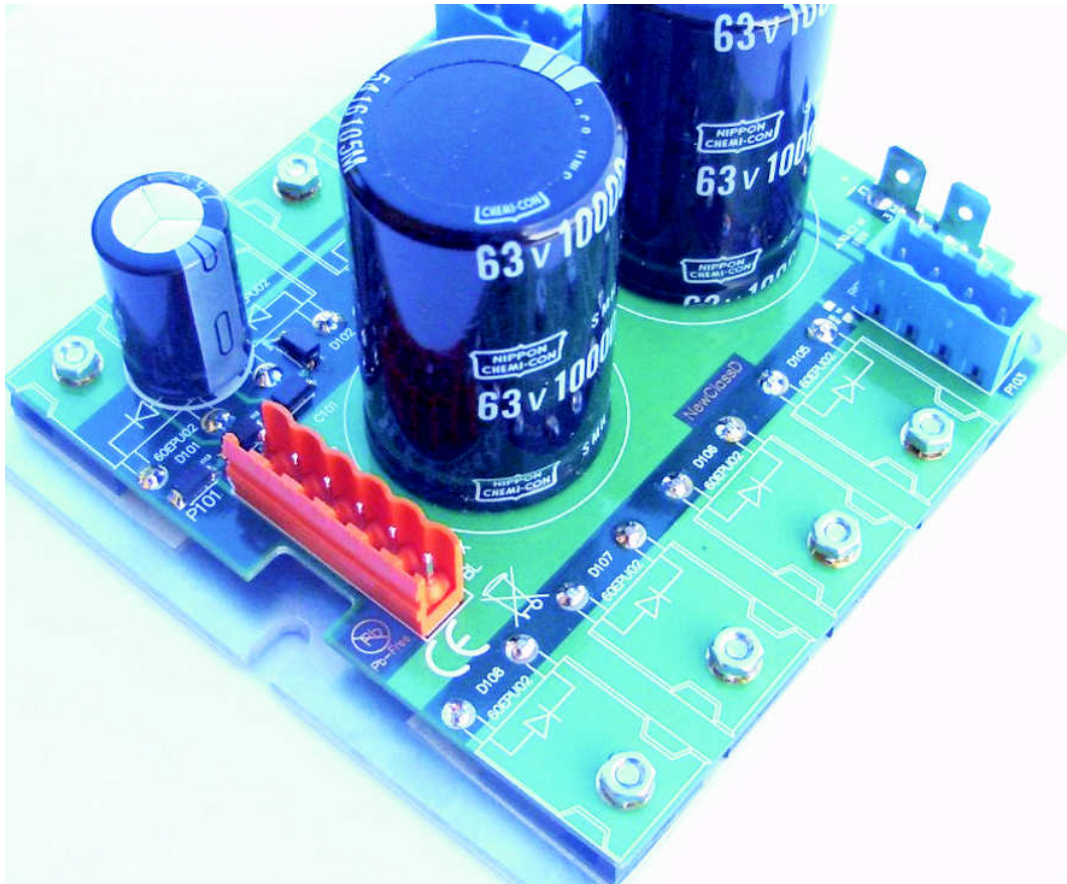

### Sound Properties of Cables.

The sound properties of the input cables, however short, is of great importance to the overall result of your amplifier. Use the best cables you can find, meaning those with the sound that suits you best. Don't use standard mounting wire here! You can use a shielded or unshielded cable if the distance is short, like 2-3 inches or 5-7 cm. At longer distance, use shielded cable. Uninsulated wire is very good if the distance is very short, otherwise wires insulated with organic material, or PE are the best options soundwise.

### Connection of Amplifiers to Output Terminals.

Before connecting the speaker cable, it's a good idea to check the speaker terminal for continuity to the case. If there is any connection, you MUST take the terminal out, and remove the debris that is shorting the terminal to the case.

Use good quality loudspeaker cable, and do not strip them together with input wires or transformer wires. Be careful to get the polarity of the output and GND right. Output goes to the RED speaker terminal, while GND goes to the black or white terminal.

As a rule of thumb keep all wiring in 3 separate categories, and also physically separated: Transformer wires, Input audio wires, and Output speaker wires. DC carrying power supply wires are less critical, and can be mixed with any of the above 3 categories.

### EMC Considerations.

The NewClassD modules will normally not cause any disturbances to your radio or TV reception. However since this is a DIY module, the implementation can in some cases lead to disturbance, in the form of increased background noise on FM receivers standing right next to the amplifier. For example the speaker wires may pick up on some RF signal inside the enclosure, and transmit it out to the speaker wire outside, that will then work as an aerial. Therefore - in case you see any problems - we recommend using the above EMC network, which will block any RF emittance from exiting your amplifier. A kit is available from NewClassD free of charge for all who have NewClassD modules. In the last 5 years with thousands of NCD modules running in the field we have had only a handful of cases where this EMC filter was necessary.

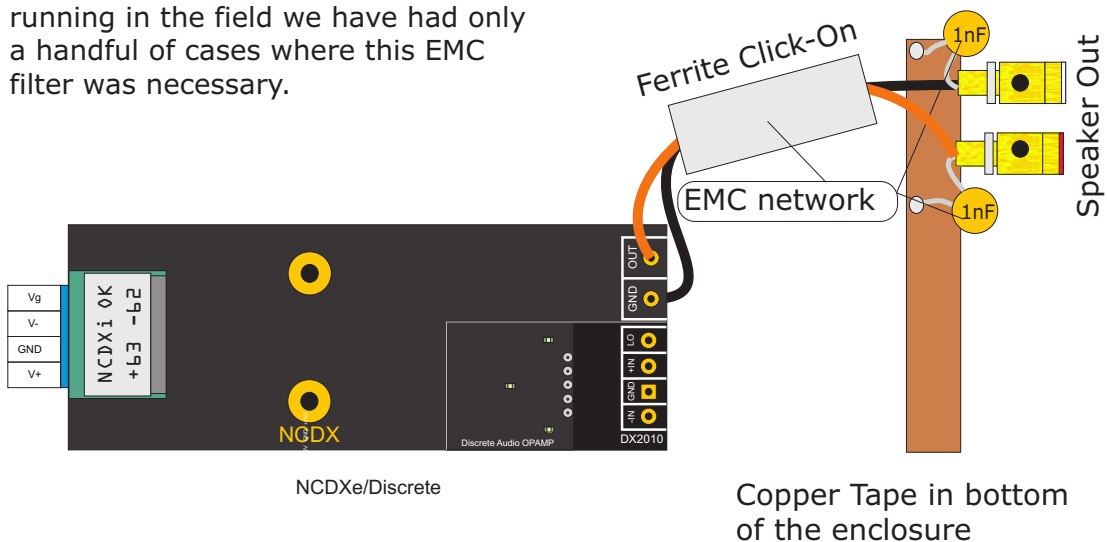

High speed soft recovery diodes are standard on all our power supply modules. They will ensure the sound is clean and free of power supply noise.

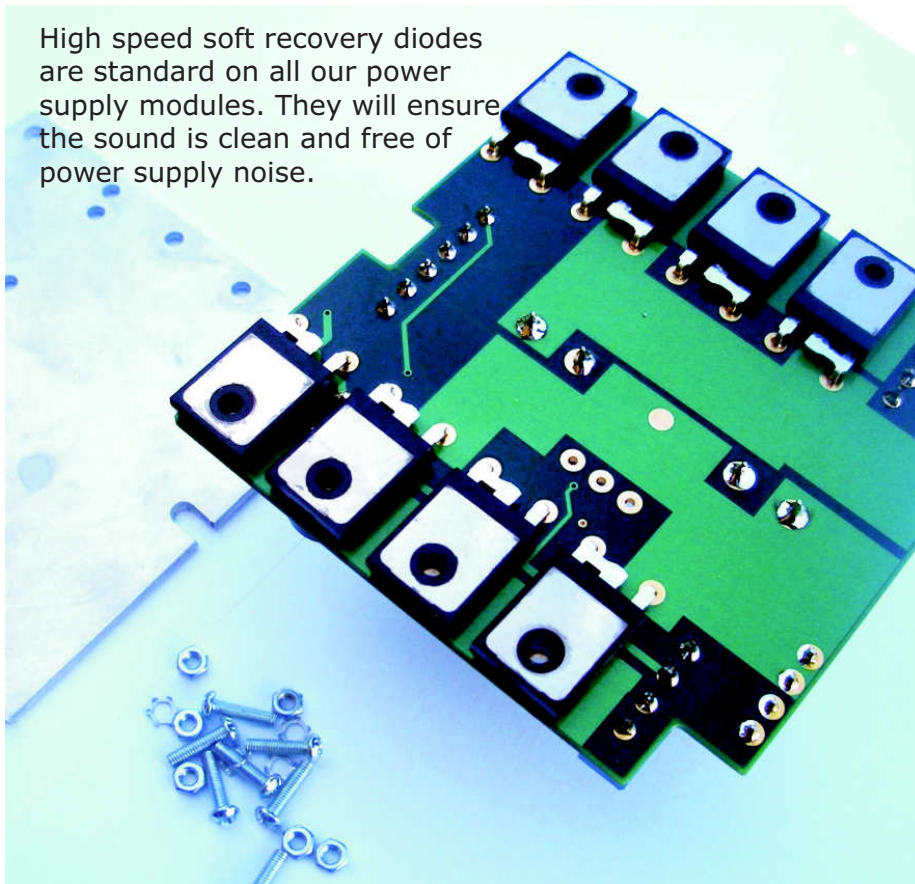

5..Double check that:

The modules are fixed in position with good contact to the cooling surface and...

The wires are fast in place, and none of them are loose in the connector.

Then connect your speakers (for first trial, you may want to use some old speakers, in case there is a problem with the wiring.).

Also connect your signal source, like network player, CD player, preamplifier or THX processor. Turn the volume DOWN.

NOTE: If your bass membranes start moving out or in when you apply power, turn off again IMMEDIATELY. Most speakers will not take damage from a second or two of DC load, but minutes will damage any speaker.

If you hear a loud humming noise, or loud pops in the speakers, turn off IMMEDIATELY.

A very subtle click is normal at power on, and is of course safe.

6.. Turn the power on, observe the blue LED 's blink for a second, then the sound is on, as the LED 's light up solid.

7..The first time you switch on your new amplifier, keep a good eye on it for a half hour. Make sure the heat sinks are not getting hotter than you can keep your hand on them constantly. (About 55 deg C). Listen for irregular pops or loud noise in the speakers. Every NewClassD module has been running at various power for at least one hour before it is shipped. Every aspect of the amplifier is tested and adjusted for optimal performance.

8..That 's it ! Enjoy one of the world 's best Class D amplifiers...

### Technical informations.

#### Residuals.

Residuals come from the internal switching of the NewClassD amplifier (120Vpp square wave of 500 kHz) filtered by the second order output filter of about 160 kHz corner frequency.

With 500kHz / 160kHz you have around 2.5 octaves of 12dB damping.

Around 30 dB under the 120 Vpp. This results in around 4 Vpp residuals left on the output terminals. This is in no way harmful for your loudspeaker, and is quite normal. The residual could arguably be reduced by using a 80 kHz or 30kHz filter instead (like some other brands of Class D modules), but then that also severely limits the output bandwidth.

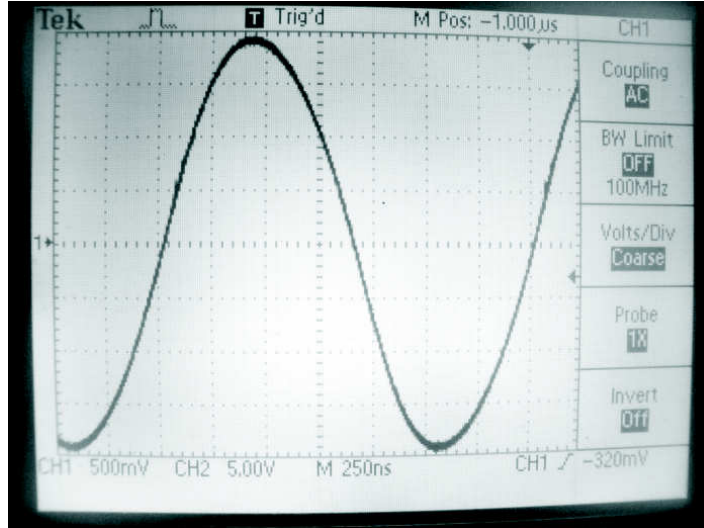

Actual residuals on a typical NewClassD amplifier. At factory level we check every module has lower than 4.5Vpp residual, at about 500 kHz. This will not be able to harm your speakers, or reduce performance of your tweeters.

## Options.

By this time your amplifier should be fully operational, and you should play on it for a few days before trying out the various options. It will take some time for the Power Supply caps to break in, and give a good sound, so don't be scared if the sound is not good in the first hour or so.

## Feedback.

You can change feedback topology on NewClassD amplifiers. This is following countless discussions on world forums about whether post or pre filter feedback is better.

In Post filter feedback mode the audio feedback signal is taken after the output filter, effectively including the output coil in the feedback loop. The good news is that you get a frequency response that is virtually independent of the load impedance. At least in theory. The bad news is, that the speaker's back EMF will now inject a signal into the feedback loop. This results in less dynamics, and less openness in the soundstage. How big the problem is, depends on your loudspeakers.

In Pre filter feedback mode the feedback signal is taken before the output coil. This effectively isolates the speaker's back EMF, from the feedback loop, and so you get better dynamics, and more openness. The bad news is that your frequency response is now load dependent. But for one thing the response is already in the area of 160 kHz -3dB, so it will take a lot of load, to get to 20 kHz. Another thing is, that an actual loudspeaker is not resistive, but mostly inductive load. This negates the effect of load dependent frequency response.

All in all we recommend the 'pre' filter mode as the best sounding, and most stable. If you are in doubt, just leave it in 'pre' mode.

To select 'pre' filter mode, [default] place a solder bubble on the 'pre' pad. To select 'post' filter mode, remove the solder from the 'pre' pad and place some solder on the 'post' pad instead. You will find these pads near the audio input. **NEVER** place a solder bubble on both pre and post.

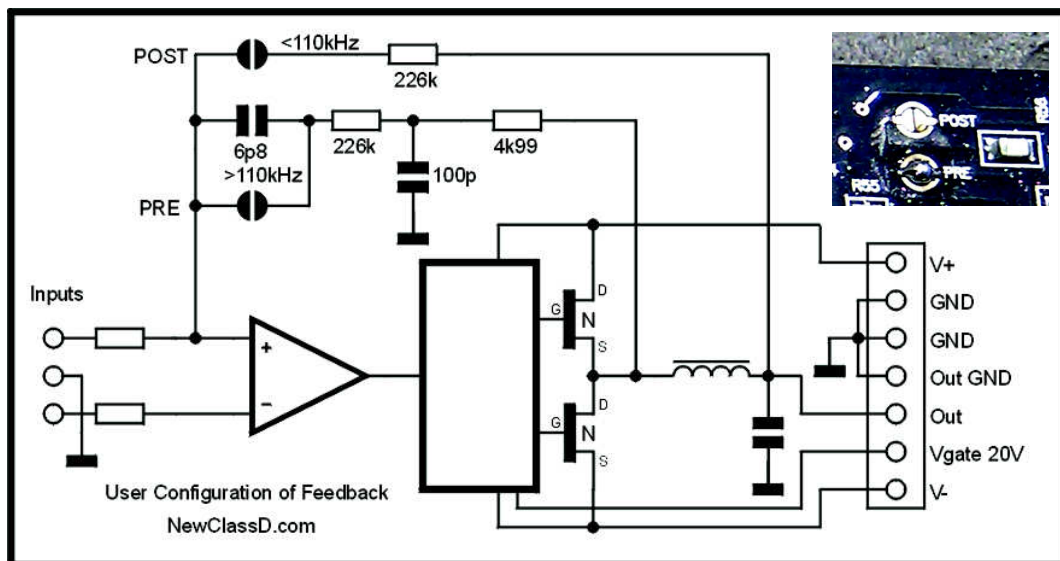

### Using a tube preamplifier.

Tube preamplifiers usually have relatively high signal output level, and also they can cause temporary DC noise on the output at power-on. You can make your NewClassD amplifier tube-ready.

To connect your NewClassD to a Tube preamplifier, reduce the sensitivity by adding a series resistor to the input (good quality), and also connect a small MKT 1-4.7uF in series with the input, to make the amplifier immune to the tube preamplifier's DC bump during power-up.

DO NOT use a big sized speaker capacitor in this position! It will act as an arial for RF noise, and cause the ClassD amplifier to oscillate out of control, or increase the background noise.

To determine which capacitor is good quality for this position, place all selected types you have in mind on your workbench. Take a big magnet, and place it on top of the capacitors.

Lift the magnet away. The types that are still on your workbench are good for Audio. The others are probably not. In other words, use a non-magnetic MKT type.

On the NCDX Discrete version we have already placed these components on the board, so you just need to connect the input signal to the >LO< terminal. Meaning LOW GAIN.

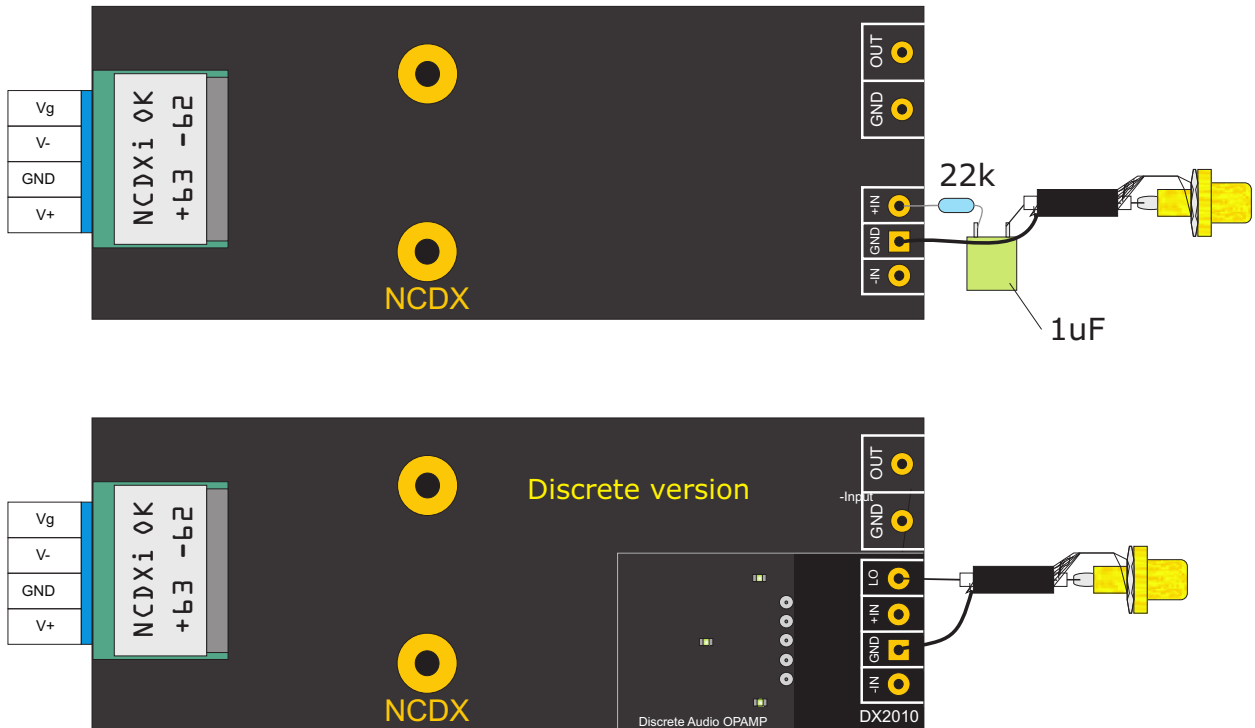

## Volume Control.

You can add a volume control to your NewClassD amplifier quite easily. This way you strictly don't need a preamplifier, so you can save the money, and also shorten your signal path. On the other hand you only have the one input, so it's only a practical solution in case you mostly use one signal source (i.e. CD player).



The simplest way to do this is by adding a 10k potentiometer in the signal path, effectively forming an internal passive volume control. This works nicely, but the passive volume control is often criticised for having less microdynamics, and a flat 'background' of the soundstage. To get past this, you can build a simple 'micropreamp' that performs as well as any high-end preamplifier. It takes a bit of circuitry, and also a good power supply, but on the other hand, the sound result is definitely worth the effort and cost.

## Micro Preamp

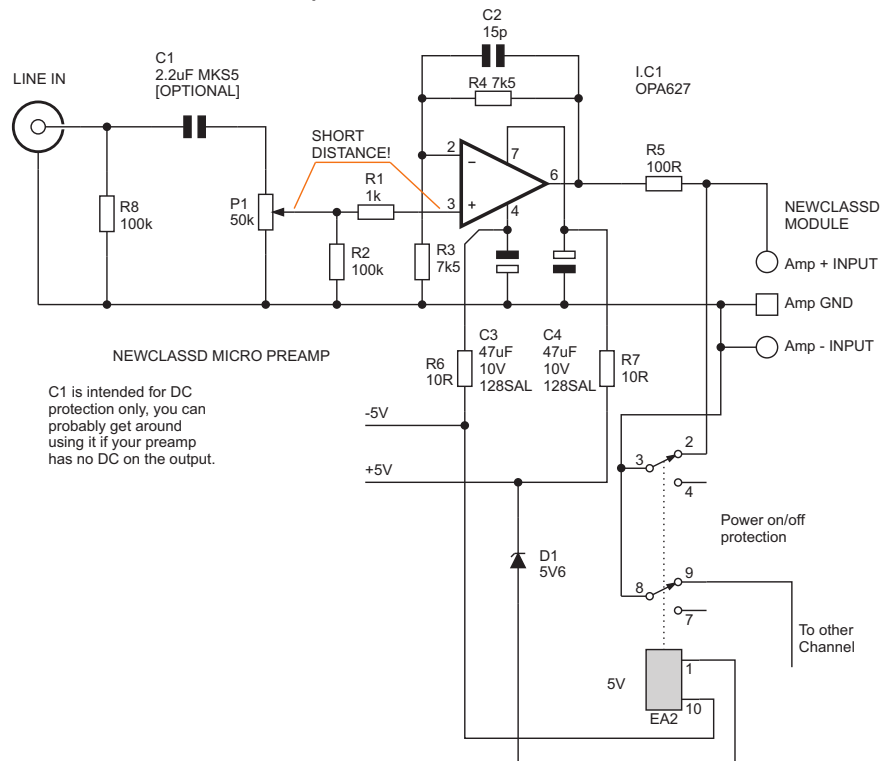



### Balanced Input. [OPTION]

Your NCD module will directly interface to a balanced input signal. Connect a female XLR receptacle (for example Neutrik Nc3-FD-H-B) to the amplifier's three input terminals.



Panel cut out (rear side)

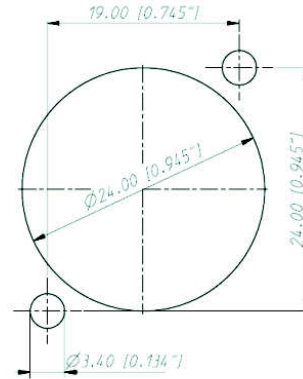

Connect pin 1 of the XLR plug to the square center pin of the amplifier.  
Connect pin 2 of the XLR plug to the + input pin of the amplifier.  
Connect pin 3 of the XLR plug to the - input of the amplifier.  
Connect the GND vane to pin 1, and also connect the 2 channel's pin 1's together with a short and solid piece of wire. This way you avoid and external hum loops.



You may connect both balanced XLR input and RCA Line input to the module simultaneously, just make sure both sets of plugs are not used at the same time.

### External power supply for the input stage. [OPTIONAL]

This is a modification for the more advanced Audio DIY'er. Whether it has any positive effect on the performance can not be determined technically, since the module already has onboard precision power supply regulators for the input stage. Never the less we are aware that some DIY'ers want to try it out as a modification. We are aware many DIY'ers have had positive results from this modification.

First you need a stable low noise power supply source of +/- 15.0 Volts. The operational limits are 14.8 - 16 V per rail. Do not attempt to change the power supply voltage beyond the below limits, to see if the sound changes. The amplifier may become unstable or even be damaged.

We recommend using our Dual Tracking Regulator for this purpose, it is optimal both in performance and specification.

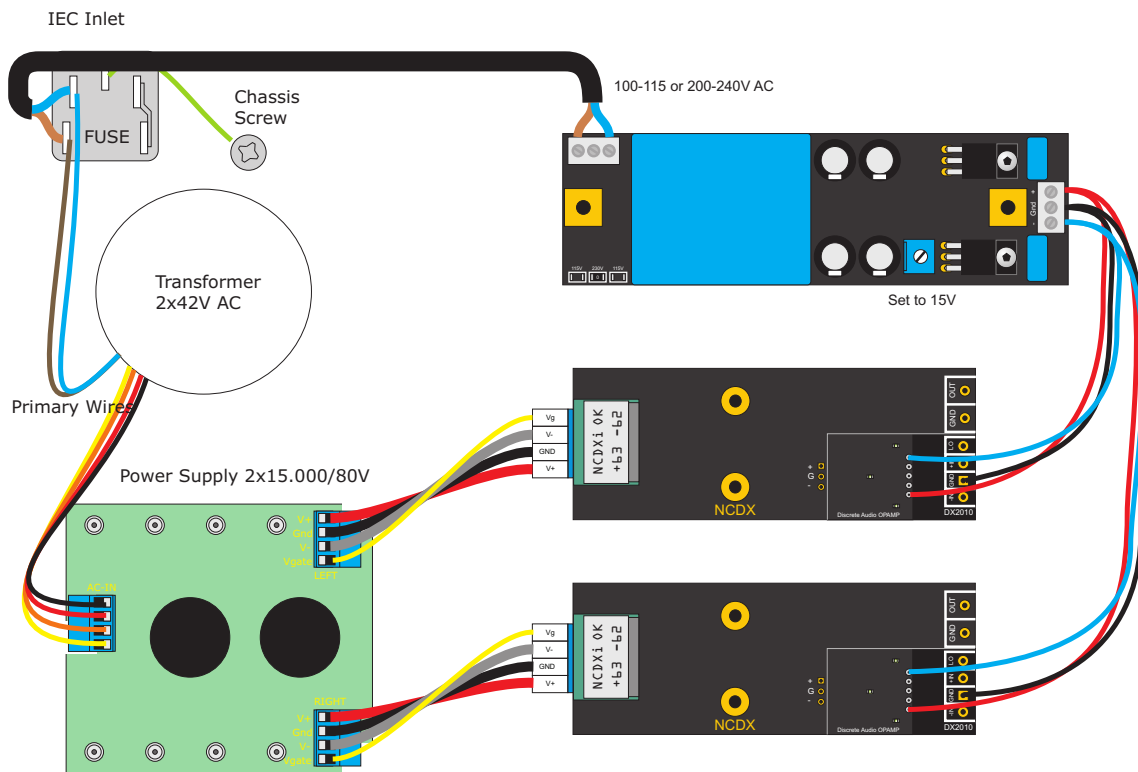

## External Analog Supply for NCDX Discrete

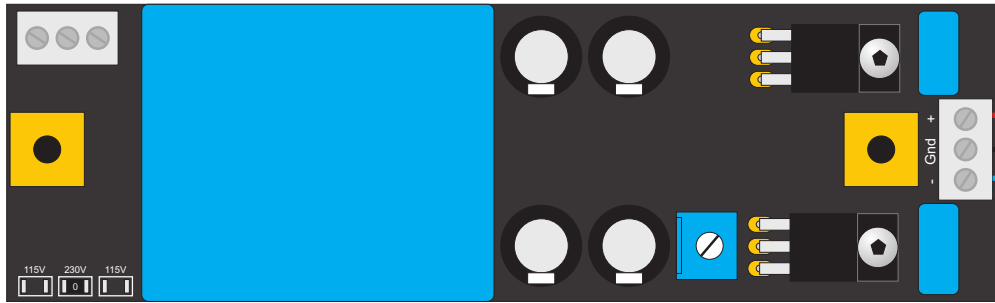

Set to 15V

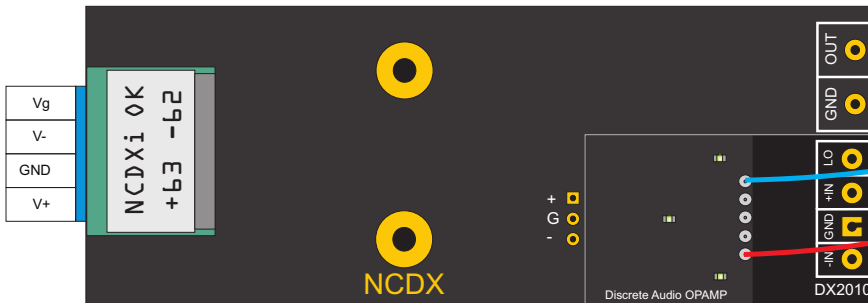
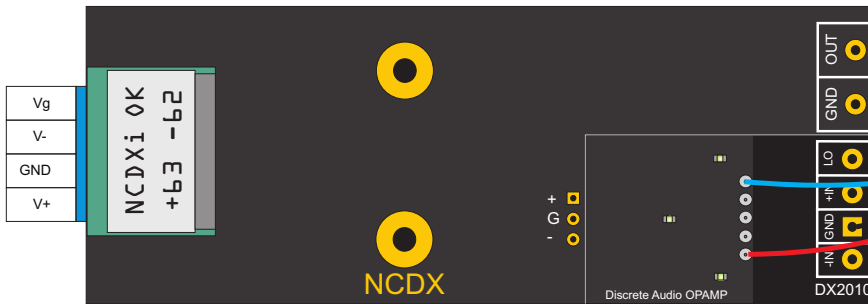

Here shown the low voltage connections only. Remember the short GND wires shown on the RCA connectors page 5 (LEFT to RIGHT) also.

## External Analog Supply for NCDXi-627

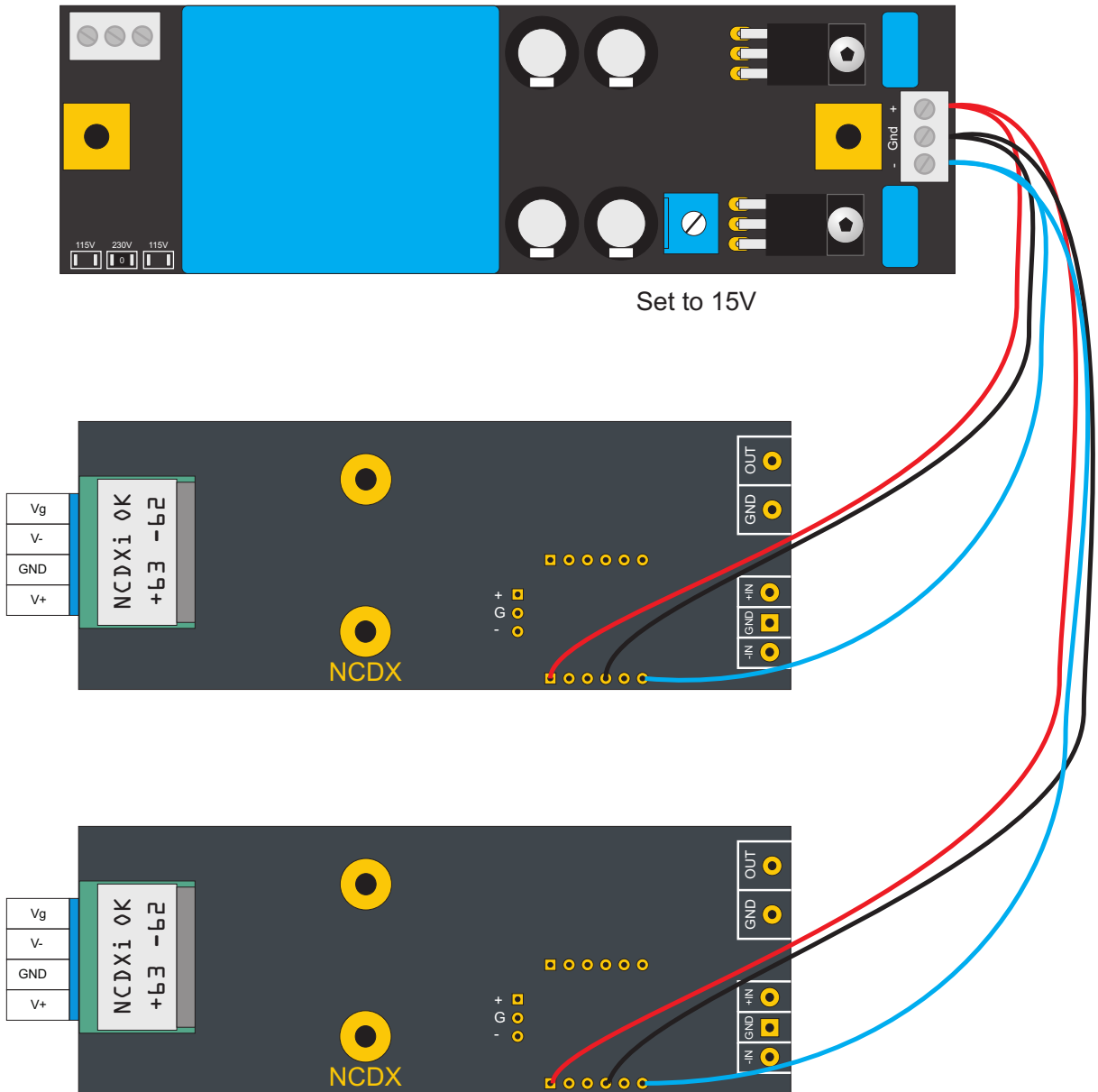

Here shown the low voltage connections only. Remember the short GND wires shown on the RCA connectors page 5 (LEFT to RIGHT) also.

## DUAL MONO setup. [OPTIONAL]

To optimise the sound quality, you can use a separate power supply and transformer for each amplifier channel. If you do that, and still place both channels in the same enclosure, you then have a DUAL MONO amplifier. Here is how it's done:

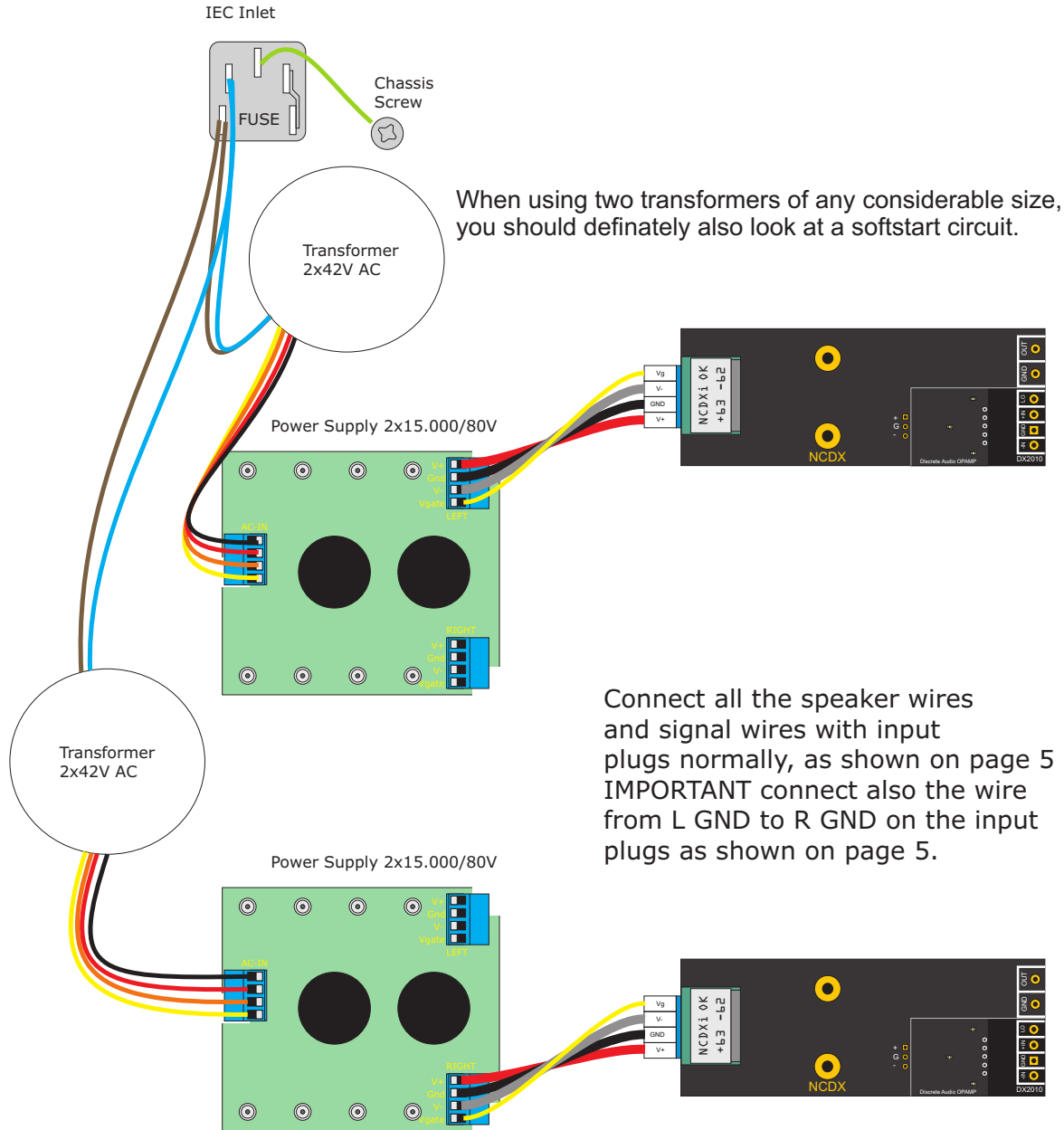

As you see it's quite easy to do, all you need is a normal stereo set of NewClassD's with PSU module, and an extra PSU module, and extra transformer. This is because each PSU module should be fed with it's own mains transformer. On the other hand, the transformer now only has to run one channel, and thus can be smaller in size (we recommend > 200 VA per channel ).

### Using 4-pole capacitors. [OPTIONAL]

The use of special Audio Grade 4-Pole capacitors can enhance the sound quality of any amplifier, also the NewClassD. A 4-Pole capacitor effectively cuts off any high frequency noise from the power supply, making way for greater tranquility and microdetail in the listening experience.

The 4-Pole capacitors can not fit onto the NewClassD power supply PCB, but can fairly easy be mounted between the PSU and amplifier module. We then suggest to glue the 4-Pole capacitors in position, and connecting the terminals using a good quality solid core wire, of ~12 AWG (2.5 mm<sup>2</sup>).

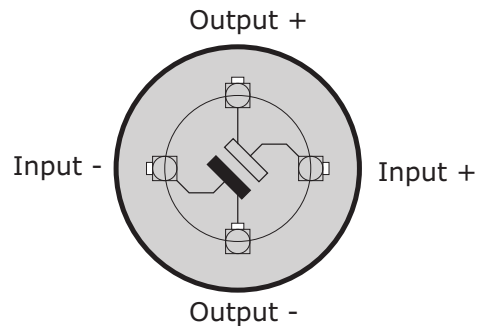

### Pin Connections for the 4-Pole Capacitors

The 4-Pole capacitor has both input and output terminals. This should not confuse you, because it simply means, the power goes into the capacitor on one set of terminals, and out on another. The current then travels through the capacitor, before it goes to the amplifier. The result is that seen from the amplifier, the capacitor effectively has no series inductance, but only capacitance. We recommend using DEXA 4 pole capacitors or similar.

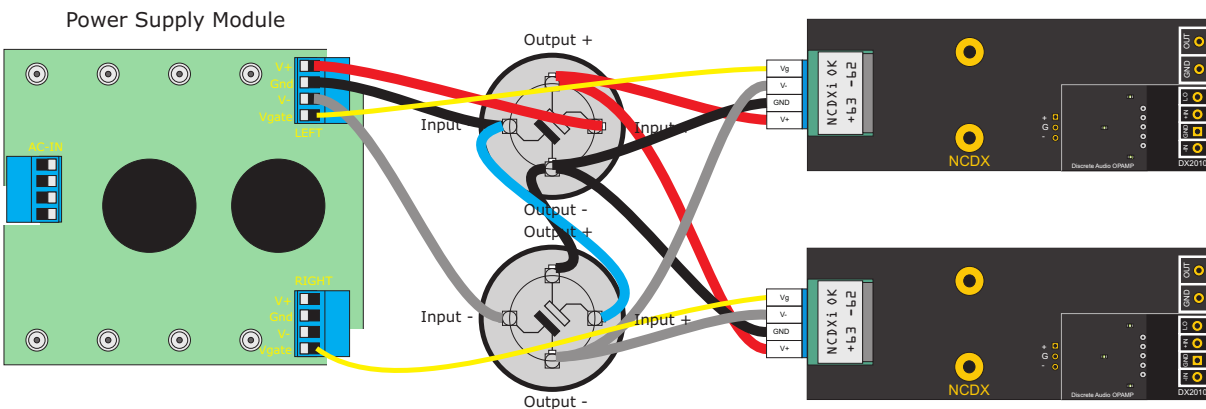

**NOTE:** Plastic decoupling capacitors are no longer necessary, as they are now placed on the module itself.